

# CP126

## JAWS FOR EXTERNAL FORM HOLDING

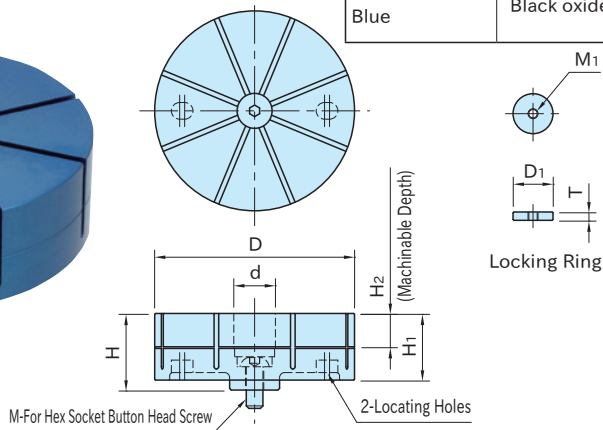

Jaw	Locking Ring
A7075 aluminum Anodized Blue	S45C steel Black oxide finish

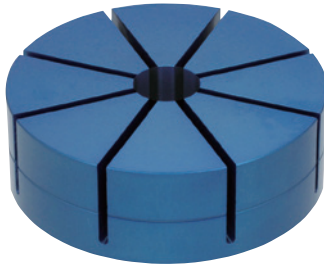

Part Number	D	d	H <sub>1</sub>	H <sub>2</sub>	M	H	M <sub>1</sub>	D <sub>1</sub>	T	Weight (kg)	Proper CP125 Clamps
CP126-06501	65	21	25	10	M 8×20L Across Flats 5	29	M5×0.8	20	4	0.2	CP125-06501
CP126-09001	90	25	35	15	M10×25L Across Flats 6	40	M6×1	24	5	0.5	CP125-09001
CP126-12001	120	25	40	20		1.1				CP125-12001	
CP126-16001	160	29	45	25	M12×25L Across Flats 8	52	M8×1.25	28	6	2.2	CP125-16001

### Supplied With

- 1 pc. of O-ring
- 1 pc. of Locking Ring
- 1 pc. of Hex Socket Button Head Screw

### Feature

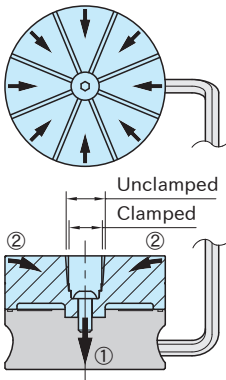

- The diaphragm clamping mechanism allows securely clamping a part with 8 jaw sections.
- 0.15mm clamping stroke of each jaw section is perfect for clamping of lost-wax parts, die-cast parts, extruded parts, solid-drawn parts, prefinished parts, etc.

- ① When the cam cylinder is tightened, the central bottom part of the jaw is pulled down.
- ② At the same time the 8 jaw sections tilt toward the center to clamp the external form of workpiece.

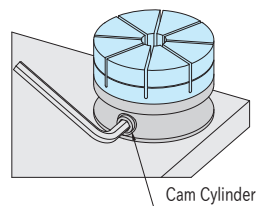

## How To Use

### 1. Jaw Mounting

- Insert an O-ring to the groove on top surface of the Form Holding Clamp.
- Set a Jaw putting its locating holes onto the round locating pins and fix it with a hex socket button head screw.

Note: At jaw installation, ensure the cam cylinder is fully loosened by turning counterclockwise until it stops.

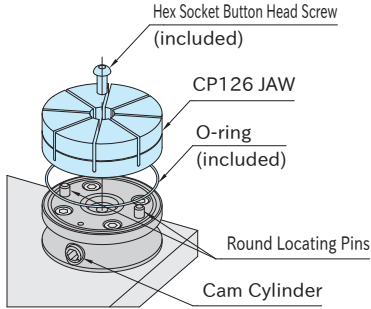

### 2. Jaw Machining

- 2-1. Set the locking ring in the jaw.  
(Using a screw facilitates setting.)

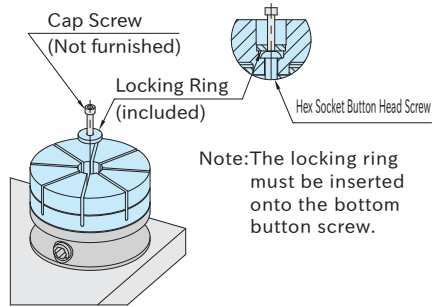

- 2-2. • Tighten the cam cylinder to clamp the locking ring. (Recommended Tightening Torque:  $15\text{N}\cdot\text{m}$ )  
• After clamping the screw should be removed from the locking ring.

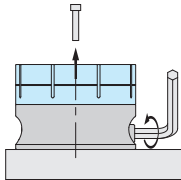

- 2-3. Machine the jaw to the contours of workpiece.  
(Do not machine the jaws beyond the machinable depth.)

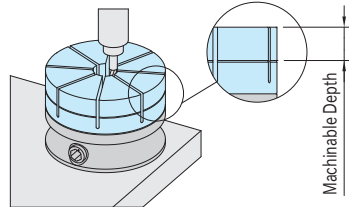

### 3. Workpiece Loading

- Loosen the cap screw to remove the locking ring.
- Load the workpiece and tighten the cam cylinder for clamping.

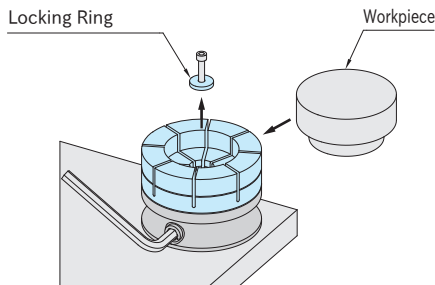

## Performance Curve

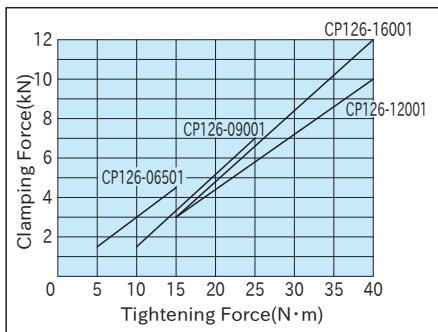

## Note

Do not tighten the cam cylinder without the workpiece set to prevent damage and deformation. Tightening with the torque beyond the allowable screw torque will lower the durability of the jaw.